

The one-line diagram must include the following:

- **Site Plan:**

The Customer must provide details on equipment capacity, type and location. Information must be clearly identified and marked to avoid confusions and delay in the technical review step. All specifications provided in the sample one-line diagram are reviewed and must be satisfied prior to technical review approval. For more information on the specifications, please follow the sample one-line diagram link provided previously in *Section 3.1/3.2/3.3* or visit *Appendix A*. The one-line diagram must comply with the DSO 1875 standard. Please see *Section 5.1 Sample One-Line Diagram*.

Note: Prior standards will not be accepted by EPE.
- **Inverter information:**

All inverters must comply with UL1741 and must be equipped with protective devices to prevent connection or parallel operation of the generating equipment unless EPE's service voltage and frequency are within standard operating ranges. The delivery service phase must be clearly specified in the one-line diagram and in the Interconnection Application. Inverter's manufacturer and model, specific power and voltage ratings must be identified.
- **A/C Disconnect information:**

A visible A/C Disconnect must be installed to allow manual interruption of electrical service from the main service panel. It must be accessible to EPE's Meter Test employees and must be equipped with protective devices to prevent connection to a de-energized circuit. The location of the A/C Disconnect must be between the REC meter and the main service panel according to the one-line diagram requirements.
- **Breaker information:**

The one-line diagram must depict the breaker rating. The breaker rating specified on the one line must match the breaker size installed at the premise.
- **Wire Size**

Wire sizing must be provided for the wires used from the disconnect to the REC Meter and from the REC to the main service.
- **Storage System information (if applicable):**

If installing a storage system, the one-line must also depict the following:

 - The energy storage type: (e.g. battery)
 - If Battery: Battery Chemistry (e.g. Lead Acid, Li-Ion, NiCa)
 - Max Storage Capacity (kW)
 - Energy Capacity (kWh)
 - Energy Storage System Voltage: (V)
 - Energy Storage Maximum Discharge Capacity: Rated maximum current at rated voltage (A)
 - Energy Storage Nominal Discharge Capacity: Rated current at rated voltage (A)
 - Specify intended use for mode of operation (Backup power, power quality, other)

- If installing a separate inverter for the storage system, please provide the following information on the one-line diagram:
 - o Inverter Manufacturer
 - o Inverter Model
 - o Inverter certification
 - o Rated output power (Watts)
 - o Maximum apparent AC output power (VA)
 - o Rated Output Voltage (V)
 - o Inverter Short Circuit Capacity (Amps or per unit), if available
 - o Provide Manufacturer specifications sheet
 - o Provide transfer switch specs

ONE LINE DIAGRAM & SITE MAP

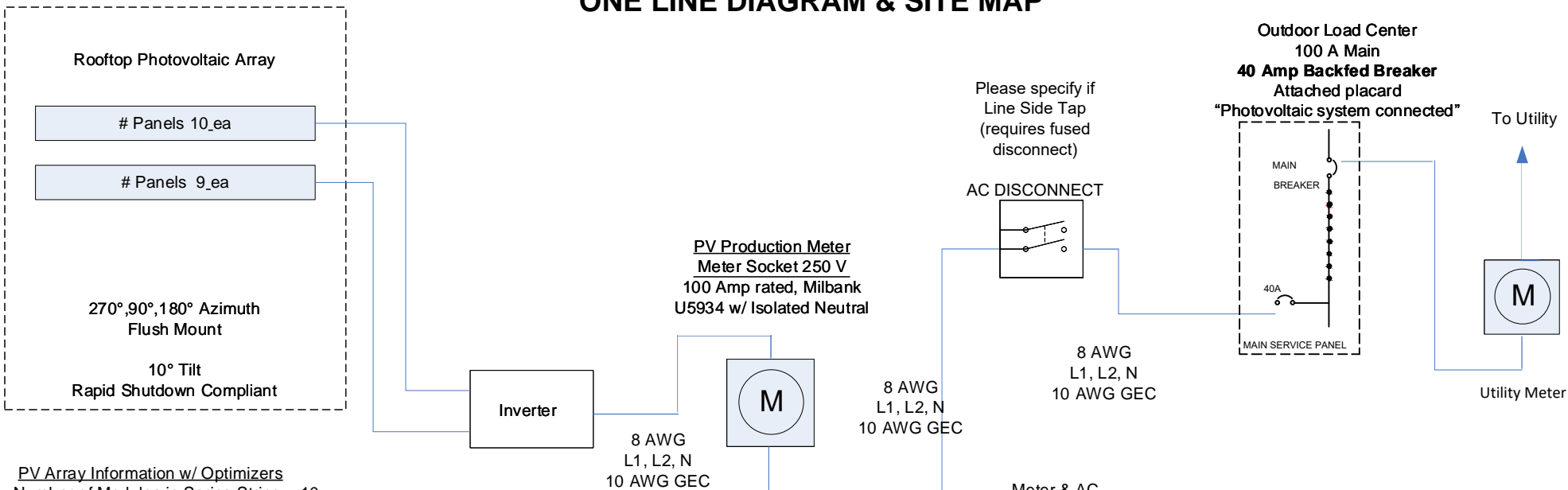

PV Array Information w/ Optimizers

Number of Modules in Series String = 10
 Maximum Current per String = 10 A
 Max DC Voltage = 480 VDC
 Max Vmp per String = 380 VDC

10 AWG Conductors 12 AWG Equipment Ground

Up to 6 Current Carrying Conductors per Conduit
 Voltage Drop < 1% if linear distance is less than 100 Ft
 3/4" Conduit or Greater

INVERTER / SOLAR PANELS INFORMATION	
MAKE AND MODEL:	
MAX DC VOLTAGE RATING	
MAX CONTINUOUS POWER	
NOMINAL AC VOLTAGE	
MAX AC CURRENT	
MAX OCPD RATING	

Notes & distances

- Weather proof one line electric diagram of generating facility will be located at the point of service connection to the utility
- PV array on roof of residence.
- All AC equipment located by Utility Meter
- Inverter located by meter
- Photovoltaic AC Disconnect to main service panel within 5'
- Main service panel to revenue meter within 5'
- Photovoltaic AC Disconnect to revenue meter within 10'
- Photovoltaic AC Disconnect is lockable and visible within sight to revenue meter

PV Module Ratings @ STC

Module Manufacturer = Axitec
 Module Model # = AXLpremium HC
 Max Power Current (Imp) = 9.35 A
 Max Power Voltage (Vmp) = 39.6 V
 Open Circuit Voltage (Voc) = 47.4 V
 Short Circuit Current (Isc) = 9.85 A
 Max Series Fuse (OCPD) = 15 A
 Maximum Power (Pmax) = 370 W
 Max System Voltage = 1000V
 Voc Temp Coefficient = -0.39 % /°C

ESTIMATED ANNUAL DG SYSTEM OUTPUT: In kWh

Notes:

1. Main Service Panel and Main Service Disconnect can be combined, either interior or exterior.
2. Qualifying facility (QF) must have a visible, lockable disconnect with 5' of main service disconnect.
3. If existing service is upgraded, changed or modified it must be brought up to current EPE standards and current local state codes.
4. Permanently post one-line diagram.
 A.Placards must be permanently placed on service indicating this an "Interconnection site", Rec Meter, A/C Disconnect.

Customer Name: Total System Size: Install Address:

Date:

Installer Name:

Phone:

Email:

Contact:

Meter & AC Equipment

